

# Current Clamp TP-CC600

## User's manual

Rev. 1.1



# Safety

**When working with electricity, no instrument can guarantee complete safety. It is the responsibility of the person who works with the instrument to operate it in a safe way. Maximum security is achieved by selecting the proper instruments and following safe working procedures. Safe working tips are given below:**

- Always work according (local) regulations.
- Work on installations with voltages higher than 25 V AC or 60 V DC should only be performed by qualified personnel.
- Avoid working alone.
- Observe all indications on the Current Clamp TP-CC600 before connecting any wiring
- The Current Clamp TP-CC600 complies with class II, over-voltage CAT II - 600 V of the EN 61010-1 and EN 61010-2-032 standards. Do not clamp around conductors with voltages equal to or exceeding 300 V DC or 240 Vrms AC.
- To avoid physical injury, measurements on bare conductors or conductors with damaged insulation are not allowed
- Check the Current Clamp TP-CC600 and test leads for damages. Do **not** use them if they are damaged
- Take care when measuring at voltages higher than 25V AC or 60 V DC.
- Do not operate the equipment in an explosive atmosphere or in the presence of flammable gases or fumes.
- The Current Clamp TP-CC600 is designed for indoor use only
- Do not use the Current Clamp TP-CC600 if it does not operate properly. Have the equipment inspected by qualified service personal. If necessary, return the Current Clamp TP-CC600 to TiePie engineering for service and repair to ensure that safety features are maintained.
- If the Current Clamp TP-CC600 is used in a manner not specified, the protection provided by the instrument may be impaired.

# Declaration of conformity

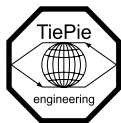

TiePie engineering  
Koperslagersstraat 37  
8601 WL Sneek  
The Netherlands

## EC Declaration of conformity

We declare, on our own responsibility, that the product

### Current Clamp TP-CC600

for which this declaration is valid, is in compliance with

EN 55011:2009/A1:2010	EN 61000-6-1:2007
EN 55022:2006/A1:2007	EN 61000-6-3:2007

according the conditions of the EMC standard 2004/108/EC.

Sneek, 1 March 2009

ir. A.P.W.M. Poelsma

A handwritten signature in blue ink, appearing to read 'Poelsma', is written over a blue horizontal line.

# Description

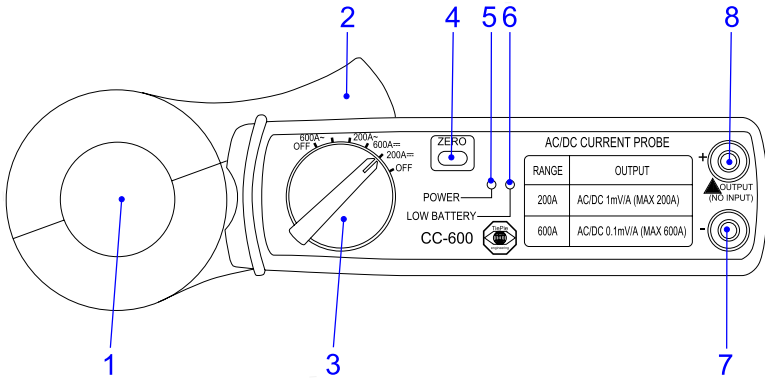

1. Transformer jaw  
Used to pick up the current signal. To measure current, the jaw must be firmly closed, leaving no air gap.
2. Transformer trigger  
Used to open the jaw.
3. Range selector switch  
Used to select the input range or switch the unit off.
4. Zero button  
This button sets the current readout to zero. This function is also used when measuring DC current to remove an offset value caused by residual magnetism in the core of the jaw.
5. Power ON/OFF led.
6. Low battery indicator  
When the indicator lights, the battery should be replaced
7. Output terminal – (black)  
This terminal is used as output for DCA – polarity and ACA.
8. Output terminal + (red)  
This terminal is used as output for DCA + polarity and ACA.

# Operating instructions

## DC current measurements

1. Set the rotary switch to 200 A DC or 600 A DC
2. Connect the negative output of the Current Clamp TP-CC600 (black) to the negative side of the input of the measuring instrument. Connect the positive output of the Current Clamp TP-CC600 (red) to the positive side of the input of the measuring instrument.
3. Switch the measuring instrument on and set it to 200 mV DC, 400 mV DC or 2 V DC full scale input range.
4. With firmly closed jaw, press the zero button until the instruments reads zero.
5. Open the jaw and fully enclose the current-carrying conductor(s) and close the jaw again, no air gap is allowed between the two halves. The output voltage is positive when the current flows from the underside to the upside of the clamp.
6. Read the measured voltage value and convert it to the corresponding current value:  
200 A range: 1 mV equals 1 A  
600 A range: 1 mV equals 10 A.

## AC current measurements

1. Set the rotary switch to 200 A AC or 600 A AC
2. Connect the negative output of the Current Clamp TP-CC600 (black) to the negative side of the input of the measuring instrument. Connect the positive output of the Current Clamp TP-CC600 (red) to the positive side of the input of the measuring instrument.
3. Switch the measuring instrument on and set it to 200 mV AC, 400 mV AC or 2 V AC full scale input range.
4. Open the jaw and fully enclose the current-carrying conductor(s) and close the jaw again, no air gap is allowed between the two halves.
5. Read the measured voltage value and convert it to the corresponding current value:  
200 A range: 1 mV equals 1 A  
600 A range: 1 mV equals 10 A.

## Battery replacement

When the low battery LED is lit, replace the old battery with a new one:

1. Turn the power off and disconnect the test leads from the Current Clamp TP-CC600.
2. Remove the screw from the battery compartment at the back of the Current Clamp TP-CC600.
3. Remove the old battery.
4. Insert a new 9 V NEDA 1604, IEC 6F22 battery.
5. Restore the battery compartment cover and tighten the screw.
6. Dispose of the old battery properly 

# Specifications

## General

Capture conductor diameter	30 mm maximum
Dimensions	
Height	209 mm
Width	43 mm
Thickness	30 mm
Weight	270 g
Connection	2 x 4 mm banana socket
Power supply	9V NEDA 1604, 6F22 006P battery
Operating environment	0°C to +50°C, <70% RH
Storage environment	-20°C to +60°C, <80% RH
Compliances	
CE	Yes
ROHS	Yes

## Accuracy

At 22°C – 28°C, <70% RH, maximum

DC 200 A range	$\pm(3.0\% + 0.6 \text{ A})$
DC 600 A range	$\pm(3.5\% + 3 \text{ A})$
AC 200 A range, 50..400Hz	$\pm(3.5\% + 0.4 \text{ A})$
AC 600 A range, 50..400Hz	$\pm(4.0\% + 4 \text{ A})$

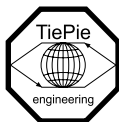

TiePie engineering  
Koperslagersstraat 37  
8601 WL Sneek  
The Netherlands

T: +31 (0) 515 415 416  
F: +31 (0) 515 418 819  
E: [info@tiepie.nl](mailto:info@tiepie.nl)  
W: [www.tiepie.nl](http://www.tiepie.nl)